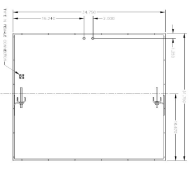
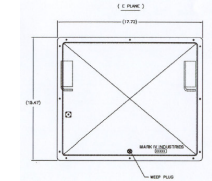
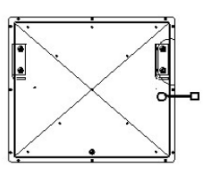
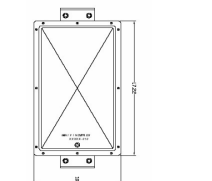
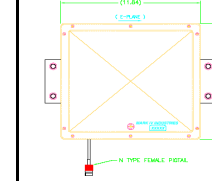

MARK IV IVHS, INC
 ANTENNA SUMMARY (IVHS WEBSITE 2008)

Parameter/Antenna	IAG-1 Antenna	IAG-2 Antenna	IAG2-T Antenna	VRC Antenna	mGate Antenna
Part #	800260-011	800260-008	800260-007	800260-010	800260-009
Lane Kit #	801692-014	801692-012	801692-009	801692-013	801300-002 (Reader Kit)
Description	3x3 patch	2x2 patch	2x2 patch	2x2 patch	1 patch
Size	34.75 x 31.75 x 2.3"	17.72 x 15.47 x 1.2"	18 x 16 x 2"	17.22 x 10.22 x 1.1"	11.84 x 10.72 x 1.22"
Weight¹	28 lbs.	4 lbs.	4 lbs.	4 lbs.	2 lbs.
Mounting	Horizontal	Horizontal	Horizontal	Vertical	Horizontal
Max. cable length²	200 ft.	150 ft.	150 ft.	150 ft.	50 ft. (with mGate Reader)
Picture					
Applications	IAG standard lane 15 ± 1 ft. height 15 deg. Tilt 10 - 12 ft. lane width	IAG wide lane 15 ± 1 ft. height 10 deg. Tilt 12 - 16 ft. lane width	IAG lane low canopy 9 - 13 ft. height Low clearance 0 deg. Tilt (flat) 10 - 12 ft. lane	407ETR lanes for IAG and TDMA 5 deg. Tilt (IAG) 40 deg. Tilt (TDMA) 12 ft. lane width	IAG low overhead mount 9 ± 1 ft. height 10 deg. Tilt 10 - 12 ft. lane width
	IAG ORT lane 16 ± 1 ft. height 15 deg. Tilt 12 ft. lane width	IAG lane low canopy 9 - 12 ft. height 12 ft. 10 deg. Tilt 9 ft.: 15 deg. Tilt 10 - 12 ft. lane	IAG wide lane 15 ± 1 ft. height Low clearance 0 deg. Tilt (flat) 12 - 16 ft. lane width	Traffic Management Overhead mount 17 - 20 ft. height, 5 deg. tilt 12 - 15 ft. lane width	
				Traffic Management Side-fire mount 17 ± 1 ft. height 30 deg. Pitch 45 deg. Yaw 12 - 15 ft. lane width	

NOTES: Mounting information is provided as a guideline. Site details may require some adjustment beyond the ranges specified.

¹Weight specified is applicable to the antenna structure only i.e. it does not include mounting hardware

²Assumes the use of Mark IV recommended feedline cable: Ultralink TL93605 from Cushcraft (4.1 dB/100 ft. loss)

For longer cable runs the use of Andrew 1/2" Heliac LDF4-50A cable is recommended (2.1 dB/100 ft. loss)



©2008 MARK IV INDUSTRIES CORP - IVHS DIVISION

All rights reserved.